

THIS DRAWING CONTAINS INFORMATION THAT IS PROPRIETARY TO J.S.T. AND SHALL NOT BE USED OR SHOWN WITHOUT WRITTEN PERMISSION.

4		3		2		1	
ITEM	CONNECTOR PART NO.	DESCRIPTION	IPI CHECK	EOR CHECK	Applicable Tooling		
1	RSFR-2-LM	RSF CONNECTOR BLACK HOUSING, W-W			APPLICATOR		
2	SIM-51T-250N	TAB-IN CONTACT – BRASS TIN-PLATED					
3	UL1015, 16 AWG	BLACK					

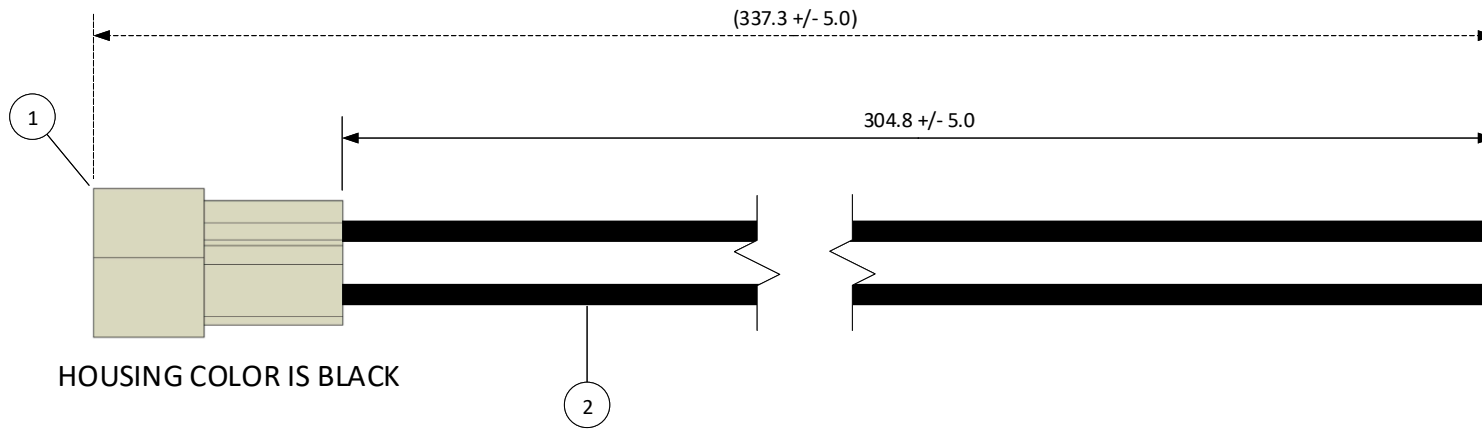

HOUSING COLOR IS BLACK

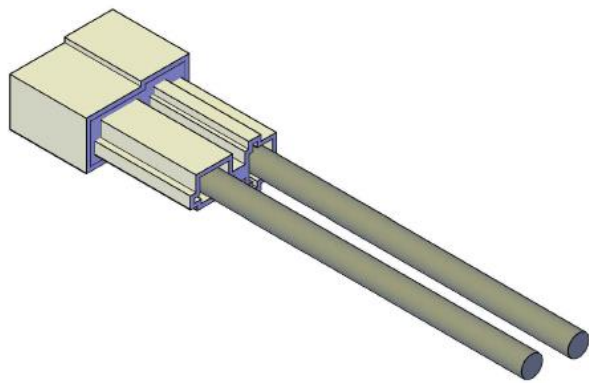

JST

SCALE 1:1	CUSTOMER NAME	CUSTOMER PART NO.
DIMENSIONS All dimensions are in MM with a tolerance of +/- 3.0 unless otherwise specified.	DESCRIPTION 12" INSIDE LENGTH – 2 POSITION, LIF, POS LOCK, .250, W-W INSULATED RECTP W/BLUNT LEADS, BLACK HSG MATES W/W-W PLUG 02RSFP16K305K	
DRAWN BY STEVEN PILKINGTON	ASSEMBLY PART NO. A02RSFR16K305K	
CHECKED BY JUSTIN BAKER	DRAWING NO. & REVISION GAM-144	REVISED 3/16/2016

REV.	DESCRIPTION	DATE	BY

4 3 2 1